

MINI AUGER DRIVE



AUSTRALIA'S PREMIER ATTACHMENT MANUFACTURER



Mini Auger Drive

From Digga's Premium Drive Range comes the most compact mini drive for tough mini machines.

Features:

- Quality Digga New Generation Gearbox & Motor
- High quality bearings and components
- 2 Ranges available, lightweight and standard

Standard Model Features:

- Convertible axis for 2 way or 4 way swing options.
- Safety Stops preventing damage to hoses, cement mixa and machines
- New Cradle Design allowing for quick cement mixa addition

Ideal Use:

Fencing, tree planting, house foundations and more.

Machine Suitability:

Mini Machines, Mini Excavators, Small Skid Steer Loaders

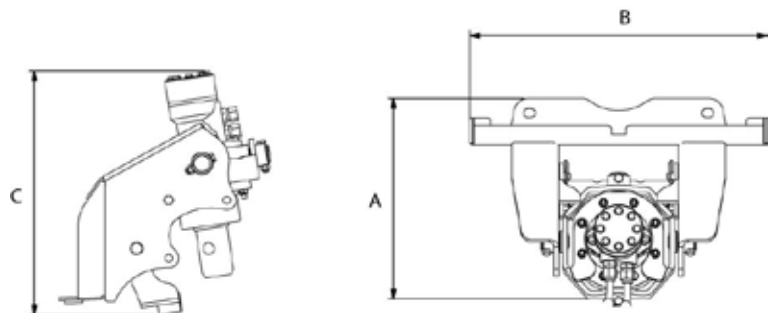

Please note: Dimension drawing depicts standard model - 4 way

Specifications	Lightweight Model (Low Flow)	Lightweight Model (High Flow)	Standard Model 2 Way (Single Swing)	Standard Model 4 Way (Dual Swing)
A Length (overall)	472mm	270mm	350mm	415mm
B Width (overall)	419mm	615mm	615mm	615mm
C Height (overall)	395mm	710mm	570mm	495mm
Max Flow (LPM)	up to 22	up to 45	20-115	20-115
Max Pressure (BAR)	186	220	240	240
Weight	37kgs	53kgs	62kgs	67kgs

Digga Have a Full Range of Premium Drives, Supa Drives and Mega Drive also available

GET ATTACHED

with an experienced partner

DIGGA Head Office

Brisbane QLD

4 Octal Street,
Yatala QLD 4207
Ph: (07) 3807 3330
Fax: (07) 3807 1499

DIGGA NSW

1 Gallipoli St, Smeaton
Grange, NSW, 2567
Ph: (02) 4647 1400
Fax: (02) 4647 1433

DIGGA VIC

21 - 25 Villas Road
Dandenong VIC, 3175
Ph: (03) 9706 6171
Fax: (03) 9706 6164

DIGGA WEST

13 Yampi Way,
Willetton, WA, 6155
Ph: (08) 9457 1544
Fax: (08) 9457 0748

Email: info@digga.com Web: www.digga.com

